

Frequency Scanned Interferometer Demonstration System



Jason Deibel, Sven Nyberg, Keith Riles, Haijun Yang

University of Michigan, Ann Arbor

American Linear Collider Workshop

SLAC, Stanford University

January 7-10, 2004



Physics Goals and Background



- To Carry out R&D toward a direct, quasi real time and remote way of measuring positions of critical tracker detector elements during operation.
- The 1-Dimension accuracy of absolute distance is on the order of 1 micron.
- Basic idea: To measure hundreds of absolute point-to-point distances of tracker elements in 3 dimensions by using an array of optical beams split from a central laser. Absolute distances are determined by scanning the laser frequency and counting interference fringes.
- Assumption: Thermal drifts in tracker detector on time scales too short to collect adequate data samples to make precise alignment.

Background – some optical alignment systems

- RASNIK system: used in L3, CHORUS and CDF
- Frequency Scanned Interferometer(FSI): used in ATLAS
[*A.F. Fox-Murphy et al., NIM A383, 229(1996)*]
- Focusing here on FSI system for NLC tracker detector



Principle of Distance Measurement



- The measured distance can be expressed by

$$R = \frac{c\Delta N}{2\bar{n}_g\Delta\nu} + \text{constant end corrections}$$

*c - speed of light, ΔN – No. of fringes, $\Delta\nu$ - scanned frequency
 n_g – average refractive index of ambient atmosphere*

- Assuming the error of refractive index is small, the measured precision is given by:

$$(\sigma_R / R)^2 = (\sigma_{\Delta N} / \Delta N)^2 + (\sigma_{\Delta\nu} / \Delta\nu)^2$$

Example: $R = 1.0$ m, $\Delta\nu = 6.6$ THz, $\Delta N \sim 2R\Delta\nu/c = 44000$
To obtain $\sigma_R \cong 1.0$ μm , Requirements: $\sigma_{\Delta N} \sim 0.02$, $\sigma_{\Delta\nu} \sim 3$ MHz



FSI Demonstration System

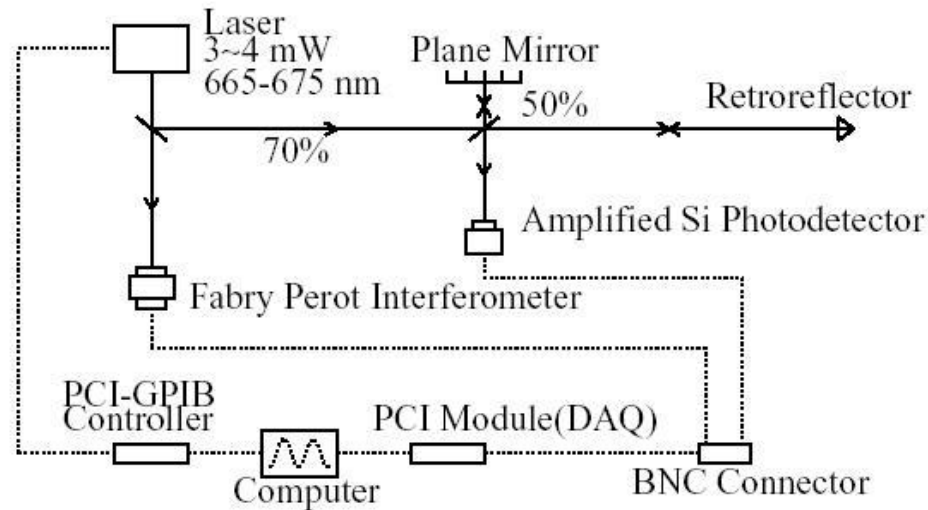

- ★ **Tunable Laser: New Focus Velocity 6308, 3-4 mW, 665.1-675.2 nm.**
- ★ **Retroreflector: Edmund, D=2", angle tolerance: ± 3 arc seconds.**
- ★ **Photodiode: Thorlabs PDA55, DC-10MHz, Amplified Si Detector, 5 Gain Settings.**
- ★ **Thorlabs Fabry-Perot Interferometer SA200, high finesse(>200) to determine the relative frequency precisely, Free Spectra Range (FSR) is 1.5 GHz, with peak FWHM of 7.5 MHz.**
- ★ **Thermistors and hygrometer are used to monitor temperature and humidity respectively.**
- ★ **PCI Card: NI-PCI-6110, 5 MS/s/ch, 12-bit simultaneous sampling DAQ.**
- ★ **PCI-GPIB Card: NI-488.2, served as remote controller of laser.**
- ★ **Computers: 1 for DAQ and laser control, 3 for analysis.**

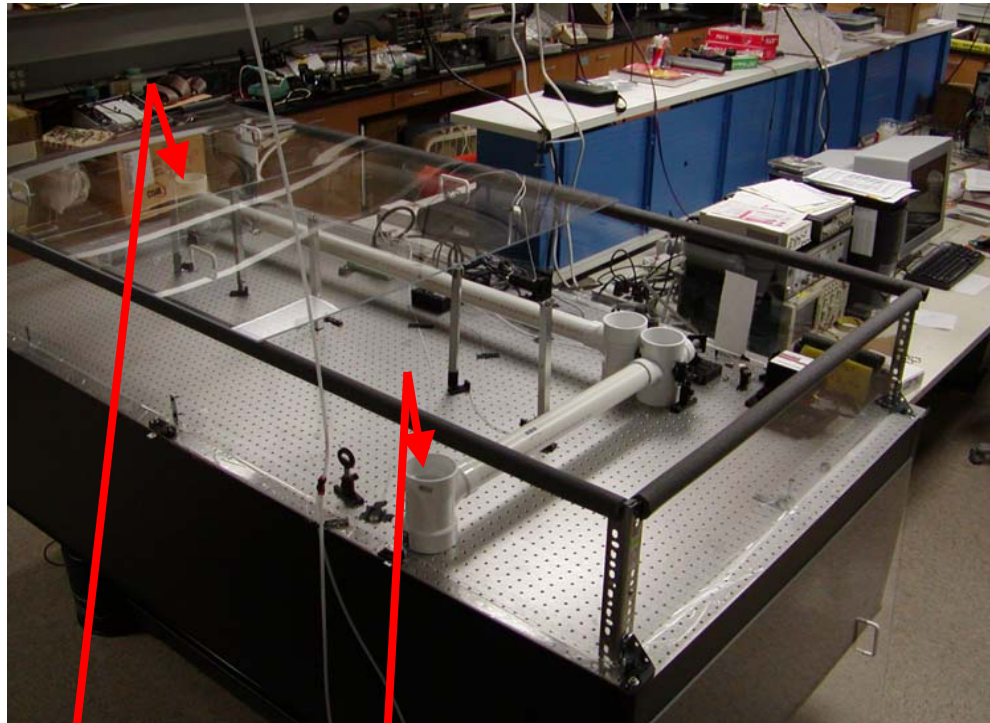

Photodetector

Retroreflector

Mirror

Beamsplitters

Laser

Fabry-Perot Interferometer

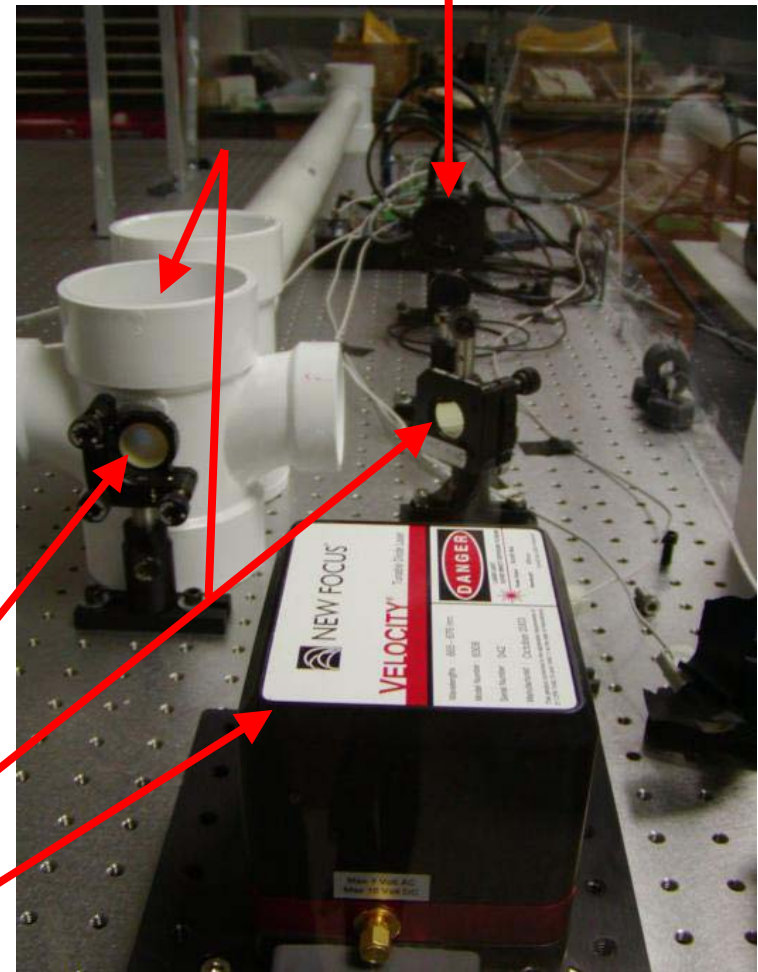



Fringe and Frequency



- Fringe is intensity oscillation of two interference laser beams while scanning.

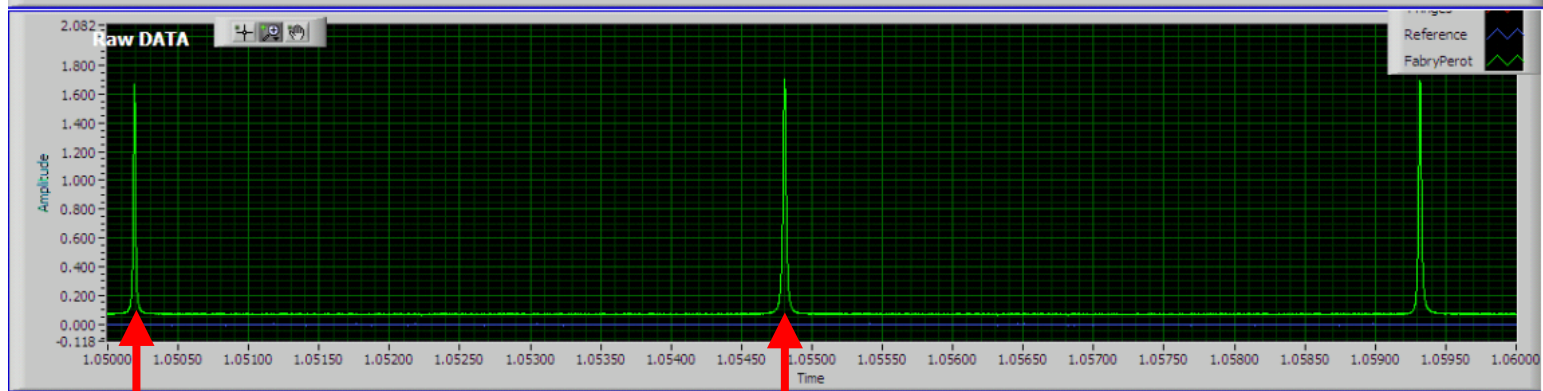
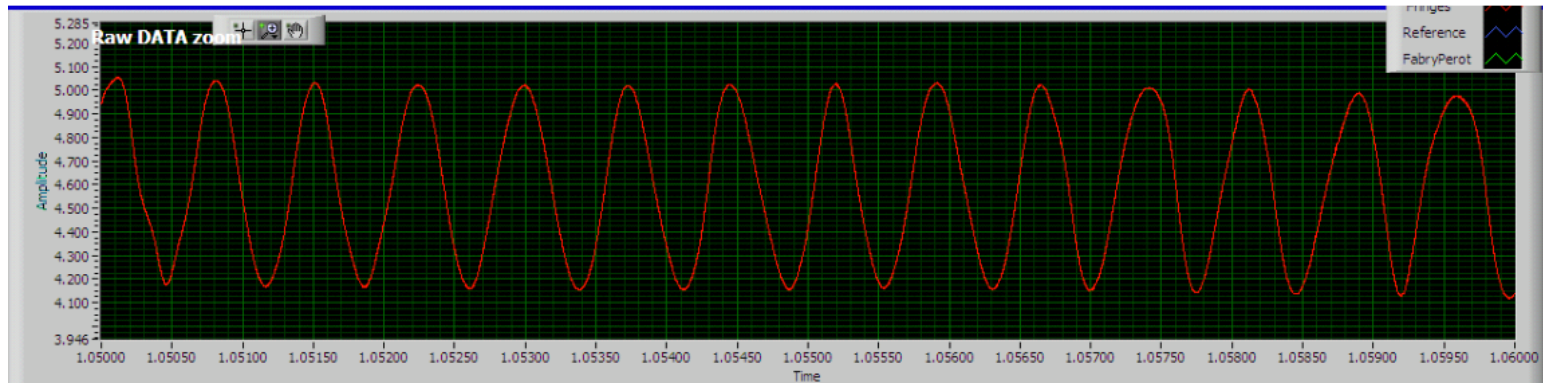

FSR = 1.5 GHz



Multi-Distance-Measurement Techniques



- Assuming a vibration with one frequency: $x_{\text{vib}}(t) = a_{\text{vib}} \cos(2\pi f_{\text{vib}} t + \phi_{\text{vib}})$
- Fringe phase at time t: $\Phi(t) = 2\pi[\text{OPD}^{\text{true}} + 2x_{\text{vib}}(t)]/\lambda(t)$
 $\Delta N = [\Phi(t) - \Phi(t_0)]/2\pi = \text{OPD}^{\text{true}} \cdot \Delta v/c + [2x_{\text{vib}}(t)/\lambda(t) - 2x_{\text{vib}}(t_0)/\lambda(t_0)]$ (1)
- If we assume $\lambda(t) \sim \lambda(t_0) = \lambda$, measured OPD can be written as,
 $\text{OPD}^{\text{measured}} = \text{OPD}^{\text{true}} - 4a_{\text{vib}} \times (v/\Delta v) \times \sin(\pi f_{\text{vib}}(t-t_0)) \times \sin(\pi f_{\text{vib}}(t+t_0) + \phi_{\text{vib}})$ (2)

Two new analysis techniques presented:

1. If the measurement window size ($t - t_0$) is fixed and the window to measure a set of OPD is sequentially shifted, the effects of vibration will be evident. The average of all measured OPD is regarded as the final value of the measured distance. This new analysis technique is called **'slip measurement window with fixed size'**. If the number of measurements is large enough, the vibration effect and uncertainties from fringe/frequency determination can be suppressed significantly.
2. In order to extract the amplitude and frequency of the vibration, another technique called **'slip measurement window with fixed start point'** was presented. If t_0 is fixed, the measurement window size is enlarged for each shift. A periodical oscillation of a set of measured OPD reflects the amplitude and frequency of vibration.



Absolute Distance Measurements



- The measurement spread of 30 sequential scans performed vs. number of measurements/scan(N_{meas}) shown below. The scanning rate was 0.5 nm/s and the sampling rate was 125 KS/s. It can be seen that the distance errors decrease with increasing N_{meas} . If $N_{\text{meas}} = 2000$, the standard deviation (RMS) of distance measurements is **35 nm**, the average value of measured distances is **706451.565 μm** . **The relative accuracy is 50 ppb.**

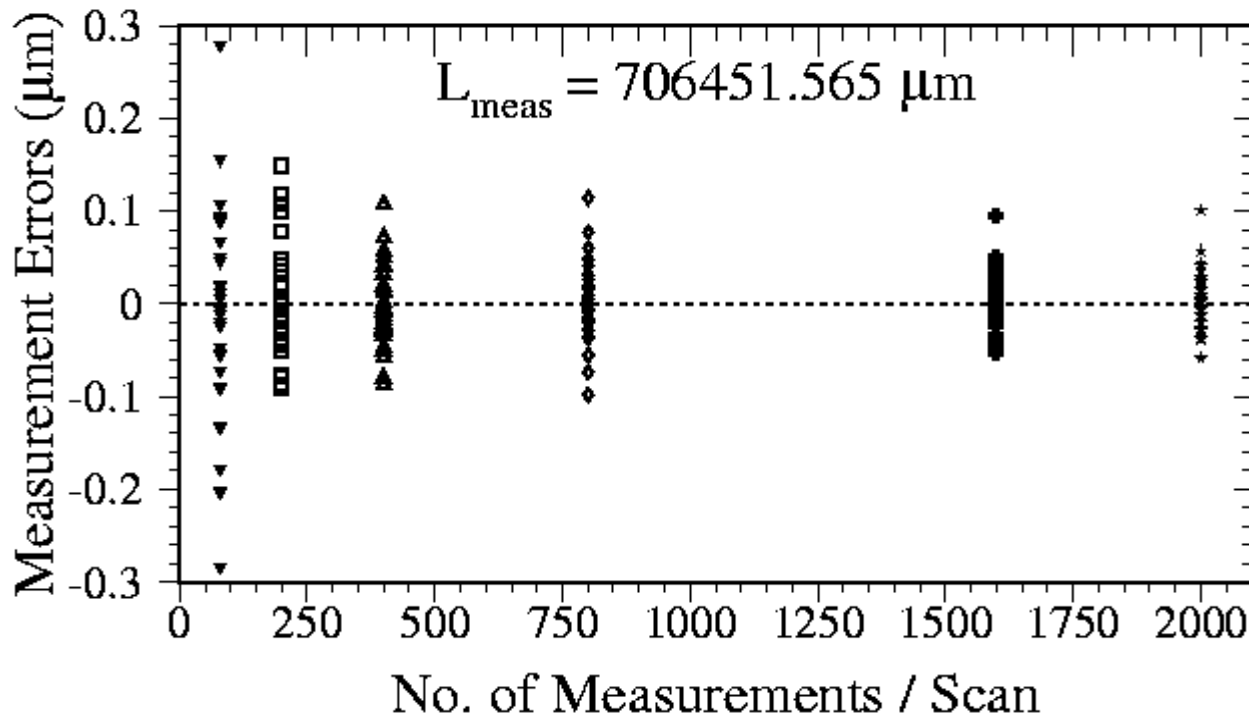



Amplitude and Frequency of Vibration



- A second analysis technique was used to extract the amplitude and frequency of vibration shown below. The amplitude and frequency fitted are $A_{\text{vib}} = 0.28 \pm 0.08 \mu\text{m}$ and $f_{\text{vib}} = 2.97 \pm 0.16 \text{ Hz}$, respectively with $\chi^2/\text{n.d.f} = 21.54/46$. Considering the vibration is magnified by a factor of $v/\Delta v$ (~ 67), the real amplitude of vibration deduced is approximately 4 nm.

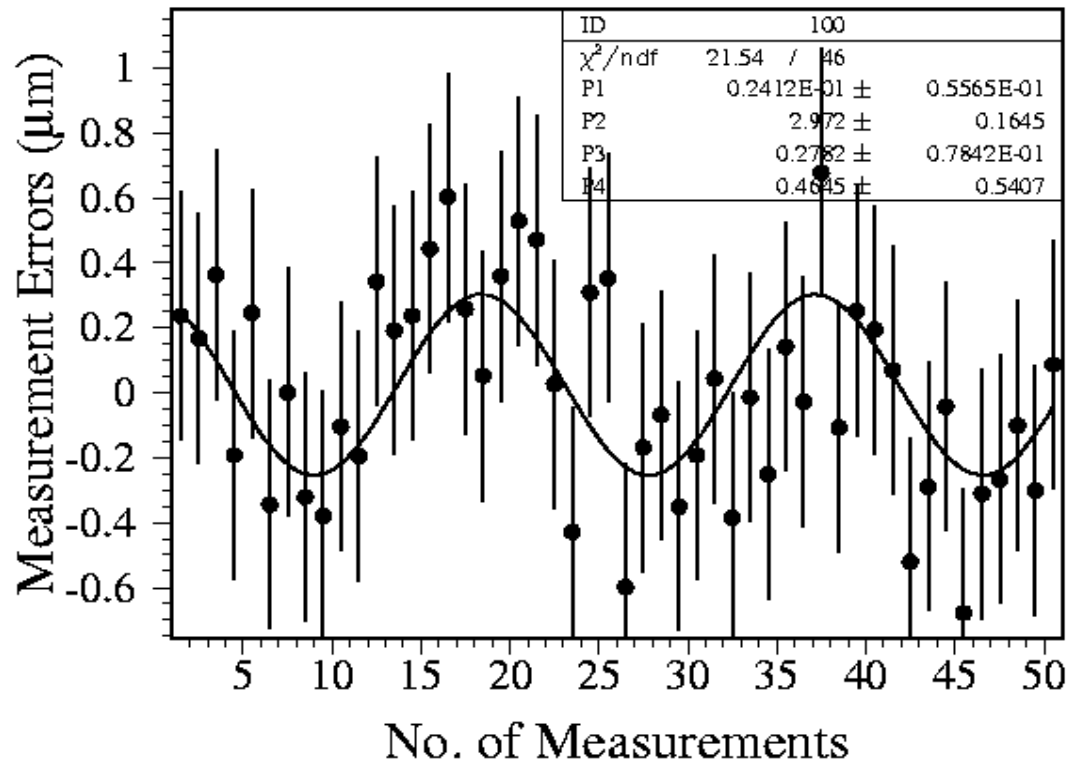



Error Estimations



- Error from uncertainties of fringe and frequency determination, $dR/R \sim 1.1$ ppm; if $N_{\text{meas}} = 2000$, $dR/R \sim 24$ ppb
- Error from vibration. $dR/R \sim 0.4$ ppm; if $N_{\text{meas}} = 2000$, $dR/R \sim 8$ ppb
- Error from thermal drift. Temperature fluctuations are well controlled down to 0.5 mK(RMS) in Lab by plastic box on optical table and PVC pipes shielding the volume of air near the laser beam. An air temperature change of 1 °C will result in a 0.9 ppm change of refractive index at room temperature. The drift will be magnified during scanning. $dR/R \sim 30$ ppb; if $N_{\text{meas}} = 2000$, dR/R is increased to ~ 40 ppb because the measurement window size is smaller for larger N_{meas} .
- Error from air humidity and pressure, $dR/R \sim 14$ ppb.

The total error from the above sources is ~ 49 ppb which agrees well with the measured residual spread of 50 ppb.



Systematic Error Estimations



- Error from fringe/frequency peak finder algorithm. If there is always one sample shift in the peak position determination, $dR/R \sim 12$ ppb.
- Error from uncertainty of FSR of Fabry-Perot interferometer which is used to determine scanned frequency precisely. If FSR is calibrated by an ultra-high precision wavemeter with a precision of 20 ppb, $dR/R \sim 28$ ppb. → But not yet measured!
- Error from uncertainty of air refractive index. The tolerance of thermistors currently used is 0.02 K, two thermistors are required to determine temperature gradient, $dR/R \sim 25$ ppb.

The total systematic error of above sources is ~ 39 ppb.



Summary and Outlook



- A simple FSI demonstration system was constructed to make high-precision absolute distance measurements.
- A high accuracy of 35 nm for a distance of about 0.7 meter under laboratory conditions was achieved.
- Two new multi-distance-measurement analysis techniques were presented to improve absolute distance measurement and to extract the amplitude and frequency of vibration.
- Major error sources were estimated, and the expected error was in good agreement with measured residual spread from real data.
- One paper, ‘High-precision Absolute Distance Measurement using Frequency Scanned Interferometer’, will be submitted to Optics Letters.



Summary and Outlook



- We are working on FSI with fibers, one fiber for beam delivery and the other fiber for return beam. Much work needed before practical application of FSI system. → Fibers necessary for remote inner tracker interferometer.
- The technique shown here does NOT give comparable accuracy under realistic detector conditions (poorly controlled temperature).
- Will investigate Oxford ATLAS group's dual-laser scanning technique.
- Michigan group rapidly coming up to speed on technology, but much work lies ahead.